



# Rexnord PSX Series Chains

## PLATINUM SERIES X (PSX) MATERIAL



Rexnord FlatTop continuously develops innovative conveyor chain and component solutions to meet the increasing performance demands of high-speed filling lines in the food and beverage industries.

### PLATINUM SERIES X (PSX) MATERIAL

Rexnord developed LF (Low-Friction) material in the 1970's to address a "high-speed" conveying concerns. In the 1990's, line speeds almost doubled and our HP™ (High Performance) material was introduced. Over time, conveyor speeds continue to increase with concerns in sustainability targeting improved safety, productivity, water consumption and reduction and energy savings. The new PSX® material addresses these needs and will help to set a sustainable conveyor standard for the future.

### APPLICATION FIELDS

PSX material is developed for high-speed conveying of glass bottles, PET bottles and cans in conditions where minimal or no external lubrication is present. Rexnord MatTop and TableTop chains in PSX material offer a long wear life with minimal dust forming in dry running applications.

### PSX Series TableTop and MatTop Chains

#### TableTop® Chain (Straight-Running)

- 820/831
- 1000 Series
- SHP325/84

#### TableTop Chains (Side-Flexing)

- 879/880/882 TAB
- 7700 Series
- RHMP Magnetflex®
- 8500 Series
- FGM 1050 Magnetflex
- FTM 1060/1055 Magnetflex

#### MatTop® Chains

- 1000 Series
- SHP325/84
- 1005 Series
- TableTop Chains (Side-Flexing)
- 1500 Series
- 879/880/882 TAB
- 7700 Series
- RHMP Magnetflex
- 8500 Series
- 1505 Series



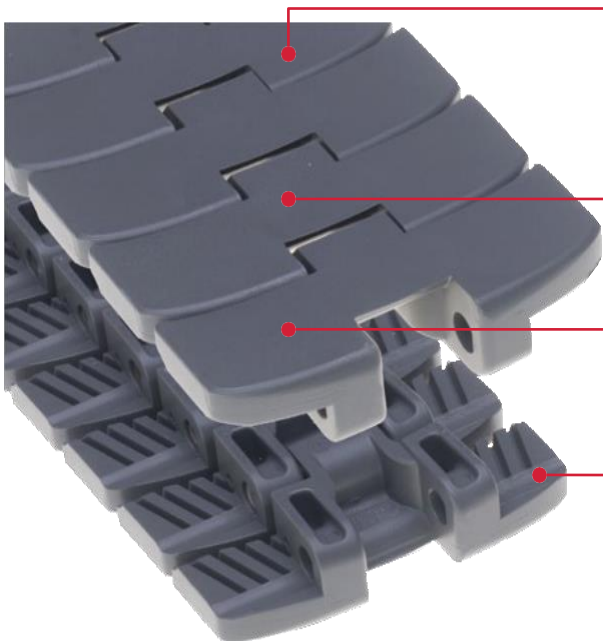

**Key Features**

- High strength
- Consistent low friction
- Minimal dusting
- Long wear life

**TableTop and MatTop Executions**

- Multiple TableTop Series
- Multiple MatTop Series

**Low-Friction Coefficient**

- PSX material offers consistent low-friction coefficient with glass, PET and aluminium cans

**Minimizes Dust**

- Minimizes dusting phenomena typically for dry running conveying

**Multiple Applications**

- Aluminium and steel can conveying
- Glass bottle handling
- PET bottle conveying



PSX FTM1060 K330 TableTop Chain



PSX FTM1060 K330 TableTop Chain in combination with ULF wearstrips

**PV (PRESSURE VELOCITY) INDEX**

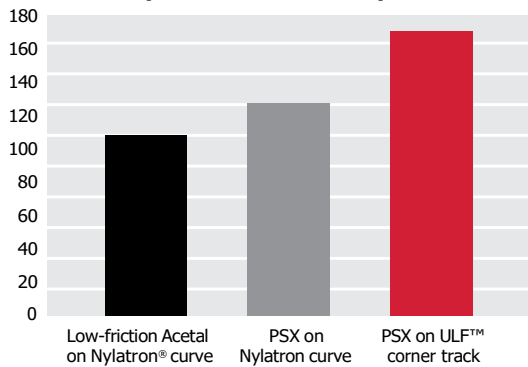

**Test conditions**

- Room temperature
- Test duration: 1.000.000 cycles
- Speed: 82/min
- Corner load: 57kg
- Dry running

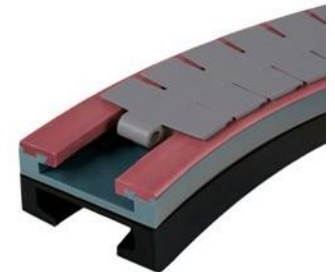

PSX Chain on a TAB X Corner Track with ULF Wearstrips

**HEADSHAFT LOAD TREND**

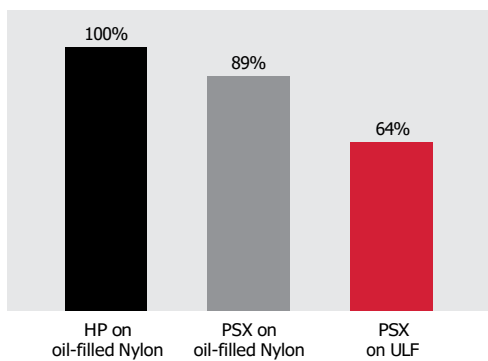

**Test conditions**

- Room temperature
- Test duration: 1000 hours
- Speed: 82/min
- Top load: 13.6 Kg
- Dry running



ULF Wearstrip (Part S0362)



rexnord.com

Contact us — visit [rexnord.com/contact](http://rexnord.com/contact)



OUR INNOVATION MOVES